



Grade Markings for Metric Fasteners

Markings of Screws (According to ISO 898 - Part I)

Property Class	3.6	4.6	4.8	5.6	5.8	6.8	8.8	9.8	10.9	12.9
Marking ¹⁾ , ²⁾	3.6	4.6	4.8	5.6	5.8	6.8	8.8	9.8	10.9	12.9

1)The full-stop in the marking symbol may be omitted.

2)When low carbon martensitic steels are used for property class 10.9 the symbol 10.9 shall be underlined: 10.9

Identification with the manufacturer's mark and the property class is mandatory for hexagon screws 3.6 to 12.9 and socket head cap screws 8.8 to 12.9 with thread diameter $d > 5\text{mm}$, where the shape of the screw always allows it - preferably on the head.

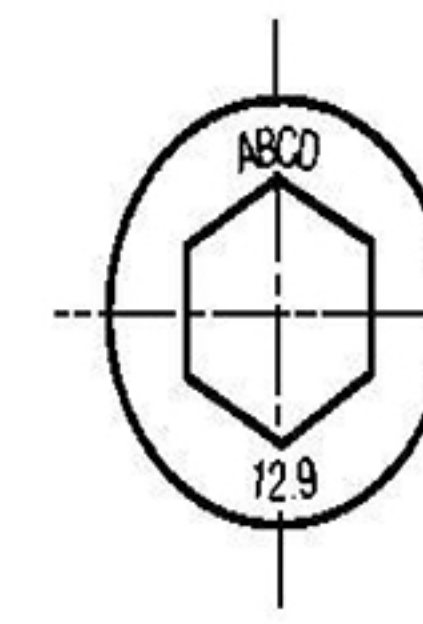
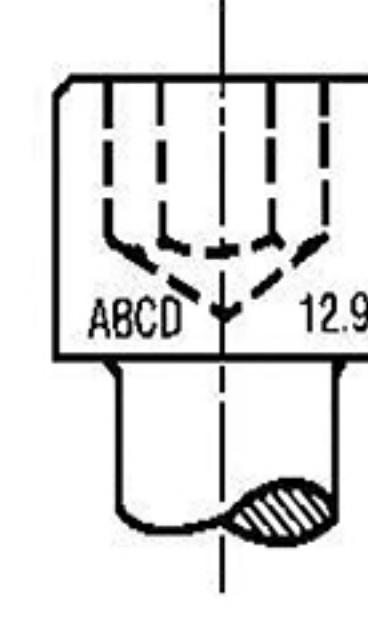
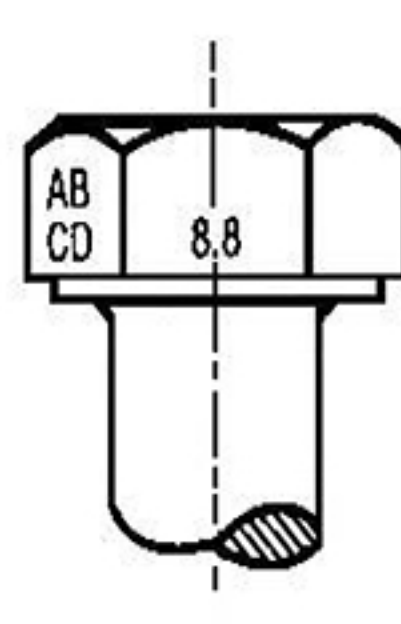
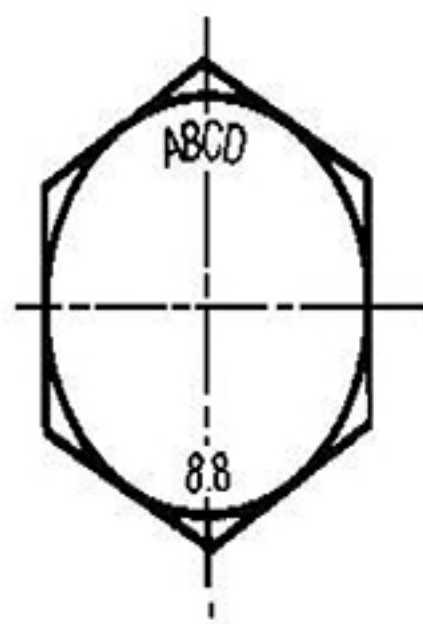

Examples of markings on hexagon screws.

Examples of markings on socket head cap screws.

Grade Markings for Metric Fasteners

Marking Of Nuts (According to ISO 898 - Part II)

Property Class	4	5	4	5	6	8	9	10	12
Either designation Symbol	4	5	4	5	6	8	9	10	12
Code (Clock Symbol) Symbol									



















Identification with the manufacturer's mark and property class is mandatory for hexagon nuts with thread diameter $d \geq 5\text{ mm}$.

The hexagon nuts must be marked with an indentation on the bearing surface or on the side or by embossing on the chamfer.

Embossed markings must not protrude beyond the bearing surface of the nut.



ASTM, SAE AND ISO Grade Markings and Mechanical Properties For Steel Fasteners

Bolts and Studs							
Identification Grade Mark	Specification	Fastener Description	Material	Nominal Size Range (in.)	Mechanical Properties		
					Proof Load (psi)	Yield Strength Min (psi)	Tensile Strength Min (psi)
 No Grade Mark	SAE J429 Grade 1	Bolts, Screws, Studs	Low or Medium Carbon Steel	1/4 thru 1-1/2	33,000	36,000	60,000
	ASTM A307 Grades A&B		Low Carbon Steel	1/4 thru 4	--	--	
	SAE J429 Grade 2		Low or Medium Carbon Steel	1/4 thru 3/4 Over 3/4 to 1-1/2	55000 33,000	57000 36,000	74,000 60,000
 No Grade Mark	SAE J429 Grade 4	Studs	Medium Carbon Cold Drawn Steel	1/4 thru 1-1/2	--	100,000	115,000
 B5	ASTM A193 Grade B5	Bolts, Screws, Studs for High-Temperature Service	AISI 501	1/4 Thru 4	--	80,000	100,000
 B6	ASTM A193 Grade B6		AISI 410			85,000	110,000
 B7	ASTM A193 Grade B7		AISI 4140, 4142, OR 4105	1/4 thru 2-1/2	--	105000	125000
				Over 2-1/2 thru 4	--	95000	115000
				Over 4 thru 7	--	75000	100000
 B16	ASTM A193 Grade B16		CrMoVa Alloy Steel			105000	125000
						95000	115000
						85000	100000
 B8	ASTM A193 Grade B8		AISI 304	1/4 and larger	--	30,000	75,000
 B8C	ASTM A193 Grade B8C		AISI 347				
 B8M	ASTM A193 Grade B8M	AISI 316					
 B8T	ASTM A193 Grade B8T	AISI 321					
 <u>B8</u>	ASTM A193 Grade B8	AISI 304 Strain Hardened	1/4 thr 3/4	--	100,000	125,000	
			Over 3/4 thru 1	--	80,000	115,000	
 <u>B8C</u>	ASTM A193 Grade B8C	AISI 347 Strain Hardened	Over 1 thru 1-1/4	--	65,000	105,000	
			Over 1-1/4 thru 1-1/2	--	50,000	100,000	
 <u>B8M</u>	ASTM A193 Grade B8M	AISI 316 Strain Hardened			95,000	110,000	
					80,000	100,000	
					65,000	95,000	
					50,000	90,000	
 <u>B8T</u>	ASTM A193 Grade B8T	AISI 321 Strain Hardened			100,000	125,000	
					80,000	115,000	
					65,000	105,000	
					50,000	100,000	
 L7  L7A  L7B  L7C  L43	ASTM A320 Grade L7	Bolts, Screws, Studs for High-Temperature Service	AISI 4140, 4142 or 4145	1/4 thru 2-1/2	--	105,000	125,000
	ASTM A320 Grade L7A		AISI 4037				
	ASTM A320 Grade L7B		AISI 4137				
	ASTM A320 Grade LC7		AISI 8740				
	ASTM A320 Grade L43		AISI 4340	1/4 thru 4	--	105,000	125,000



ASTM, SAE AND ISO Grade Markings and Mechanical Properties For Steel Fasteners

Bolts and Studs							
Identification Grade Mark	Specification	Fastener Description	Material	Nominal Size Range (in.)	Mechanical Properties		
					Proof Load (psi)	Yield Strength Min (psi)	Tensile Strength Min (psi)
B8	ASTM A320 Grade B8	Bolts, Screws, Studs for High-Temperature Service	AISI 304	1/4 and larger	--	30,000	75,000
B8C	ASTM A320 Grade B8C		AISI 347				
B8T	ASTM A320 Grade B8T		AISI 321				
B8F	ASTM A320 Grade B8F		AISI 303 or 303Se				
B8M	ASTM A320 Grade B8M		AISI 316				
B8	ASTM A320 Grade B8		AISI 304	1/4 thru 3/4	--	100,000	100,000
B8C	ASTM A320 Grade B8C		AISI 347	Over 3/4 thru 1	--	80,000	80,000
B8F	ASTM A320 Grade B8F		AISI 303 or 303Se	Over 1 thru 1-1/4	--	65,000	65,000
B8M	ASTM A320 Grade B8M		AISI 316	Over 1-1/4 thru 1-1/2	--	50,000	50,000
B8T	ASTM A320 Grade B8T		AISI 321				
	SAE J429 Grade 5	Bolts, Screws, Studs	Medium Carbon Steel, Quenched and Tempered	1/4 thru 1	85,000	92,000	120,000
	ASTM A449			Over 1 to 1-1/2	74,000	81,000	105,000
				1/4 thru 1	85,000	92,000	120,000
				Over 1 to 1-1/2	74,000	81,000	105,000
				Over 1-1/2 thru 3	55,000	58,000	90,000
	SAE J429 Grade 5.1	Sems	Low or Medium Carbon Steel, Quenched and Tempered	No. 6 thru 3/8	85,000	--	120,000
	SAE J429 Grade 5.2	Bolts, Screws, Studs	Low Carbon Martensitic Steel, Quenched and Tempered	1/4 thru 1	85,000	92,000	120,000
A325	ASTM A325 Type 1	High Strength Structural Bolts	Medium Carbon Steel, Quenched and Tempered	1/2 thru 1	85,000	92,000	120,000
				1-1/8 thru 1-1/2	74,000	81,000	105,000
	ASTM A325 Type 2		Low Carbon Martensitic Steel, Quenched and Tempered	1/2 thru 1	85,000	92,000	120,000
A325	ASTM A325 Type 3		Atmospheric Corrosion Resisting Steel, Quenched and Tempered	1/2 thru 1	85,000	92,000	120,000
				1-1/8 thru 1-1/2	74,000	81,000	105,000













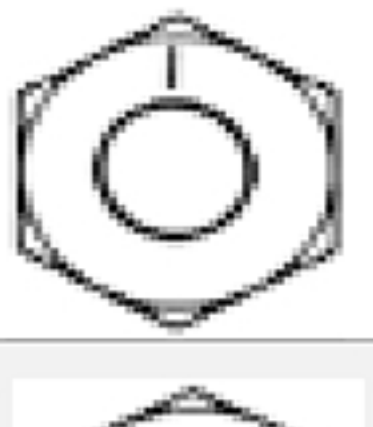

ASTM, SAE AND ISO Grade Markings and Mechanical Properties For Steel Fasteners

Bolts and Studs							
Identification Grade Mark	Specification	Fastener Description	Material	Nominal Size Range (in.)	Mechanical Properties		
					Proof Load (psi)	Yield Strength Min (psi)	Tensile Strength Min (psi)
BB	ASTM A354 Grade BB	Bolts, Studs	Alloy Steel, Quenched and Tempered	1/4 thru 2-1/2	80,000	83,000	105,000
				2-3/4 thru 4	75,000	78,000	100,000
BC	ASTM A354 Grade BC				105,000	109,000	125,000
					95,000	99,000	115,000
	SAE J429 Grade 7	Bolts, Screws,	Medium Carbon Alloy Steel, Quenched and Tempered ⁴	1/4 thru 1-1/2	105,000	115,000	133,000
	SAE J429 Grade 8	Bolts, Screws, Studs	Medium Carbon Alloy Steel, Quenched and Tempered	1/4 thru 1-1/2	120,000	130,000	150,000
	ASTM A354 Grade BD		Alloy Steel, Quenched and Tempered ⁴				
No Grade Mark	SAE J429 Grade 8.1	Studs	Medium Carbon Alloy or SAE 1041 Modified Elevated Temperature Drawn Steel	1/4 thru 1-1/2	120,000	130,000	150,000
A490	ASTM A490	High Strength Structural Bolts	Alloy Steel, Quenched and Tempered	1/2 thru 1-1/2	120,000	130,000	150,000 min
							170,000 max
No Grade Mark	ISO R898 Class 4.6	Bolts, Screws, Studs	Medium Carbon Steel, Quenched and Tempered	All Sizes thru 1-1/2	33,000	36,000	60,000
No Grade Mark	ISO R898 Class 5.8						74,000
8.8 or 88	ISO R898 Class 8.8						120,000
10.9 or 109	ISO R898 Class 10.9		Alloy Steel, Quenched and Tempered		120,000	130,000	150,000



ASTM, SAE AND ISO Grade Markings and Mechanical Properties For Steel Fasteners

Bolts and Studs							
Identification Grade Mark	Specification	Material	Nominal Size In.	Proof Load Stress ksi	Hardness Rockwell		See Note
					Min	Max	
 No Mark	ASTM A563 - Grade O	Carbon Steel	1/4 thru 1-1/2	69	B55	C32	3,4
	ASTM A563 - Grade A	Carbon Steel	1/4 thru 1-1/2	90	B68	C32	3,4
	ASTM A563 - Grade B	Carbon Steel	1/4 thru 1 over 1 thru 1-1/2	120 105	B69	C32	3,4
	ASTM A563 - Grade C	Carbon Steel May be Quenched and Tempered	1/4 thru 4	144	B78	C38	5
	ASTM A563 - Grade C3	Atmospheric Corrosion Resistant Steel May be Quenched and Tempered	1/4 thru 4	144	B78	C38	5,9
	ASTM A563 - Grade D	Carbon Steel May be Quenched and Tempered	1/4 thru 4	150	B84	C38	6
	ASTM A563 - Grade DH	Carbon Steel Quenched and Tempered	1/4 thru 4	175	C24	C38	6
	ASTM A563 - Grade DH3	Atmospheric Corrosion Resistant Steel, Quenched and Tempered	1/4 thru 4	175	C24	C38	5,9
	ASTM A194 - Grade 1	Carbon Steel	1/4 thru 4	130	B70	--	7
	ASTM A194 - Grade 2	Medium Carbon Steel	1/4 thru 4	150	159	352	7,8
	ASTM A194 - Grade 2H	Medium Carbon Steel, Quenched and Tempered	1/4 thru 4	175	C24	C38	7
	ASTM A194 - Grade 2HM	Medium Carbon Steel, Quenched and Tempered	1/4 thru 4	150	159	237	7,8
	ASTM A194 - Grade 4	Medium Carbon Alloy Steel, Quenched and Tempered	1/4 thru 4	175	C24	C38	7
	ASTM A194 - Grade 7	Medium Carbon Alloy Steel, Quenched and Tempered	1/4 thru 4	175	C24	C38	7
	ASTM A194 - Grade 7M	Medium Carbon Alloy Steel, Quenched and Tempered	1/4 thru 4	150	159	237	7
See Note 1,2	10						

NOTES:

- In addition to the indicated grade marking, all grades, except A563 grades O, A and B, must be marked for manufacturer identification.
- The markings shown for all grades of A194 nuts are for cold formed and hot forged nuts. When nuts are machined from bar stock the nut must be additionally marked with the letter 'B'.
- Nuts are not required to be marked unless specified by the purchaser.
When marked, the identification marking shall be the grade letter O, A or B.
- Properties shown are those of nonplated or noncoated coarse thread hex nuts.
- Properties shown are those of coarse thread heavy hex nuts.
- Properties shown are those of coarse thread heavy hex nuts.
- Properties shown are those of coarse 8-pitch thread heavy hex nuts.
- Hardnesses are Brinell Hardness Numbers.
- The nut manufacturer, at his option, may add other markings to indicate the use of atmospheric corrosion resistant steel.
- Specifications --
ASTM A563 -- Carbon and Alloy Steel Nuts.
ASTM A194/A194M -- Carbon and Alloy Steel Nuts for Bolts for High Pressure and High Temperature Service.



General Mechanical Properties

Property		4.6	4.8	5.6	5.8	6.8	8.8		10.9	12.9
							≤ 16mm	> 16mm		
Tensile Strength	nominal value	400	400	500	500	600	800	800	1000	1200
R _m in MPa (N/mm ²)	minimum	400	420	500	520	600	800	830	1040	1220
Vickers Hardness	minimum	120	130	155	160	190	230	255	310	372
HV=F 98N	maximum	220	220	220	220	250	300	336	382	434
Brinell Hardness	minimum	114	124	147	152	181	219	242	295	353
HB F=30D ²	maximum		209			238	285	319	363	412
Rockwell Hardness HR	minimum HRB	67	71	79	82	89				
	minimum HRC						20	23	31	38
	maximum HRB	95	95	95	95					
	maximum HRC						30	34	39	44
Surface Hardness	maximum						320	356	402	454
HV 0.3										
Yield Stress	nominal value	240	320	300	400	480				
R _{eL} in MPa(N/mm ²)	minimum	240	340	300	420	480				
0.2% elongation limit	nominal value						640	640	900	1080
R _{p0.2} in Mpa (N/mm ²)	minimum						640	660	940	1100
Test stress S _p	S _p /R _{eL} or R _{p0.2}	0.9	0.9	0.9	0.9	0.9	0.91	0.91	0.88	0.88
	MPA (N/mm ²)	225	310	280	380	440	580	600	830	970
Elongation after fracture	minimum	22	14	20	10	8	12	12	9	8
A ₅ in %										
Minimum notch impact energy in Joules				25			30	30	20	15
Head Impact Toughness										
Maximum Height of the Thread Zone Not Decarburized E							1/2H ₁	1/2H ₁	2/3H ₁	3/4H ₁
Maximum Depth of Decarburization Gmm							0.015	0.015	0.015	0.015



Mechanical Properties for Socket Products

DIN 912 Socket Cap Screws	
Property Class	12.9
Hardness (HRC)	39-44
Tensile Strength (Mpa)	1,220 min.
Yield Strength at 0.2% Offset (Mpa)	1,100 min.
Elongation (%)	8 min.

ASME B18.3 Socket Cap Screws		
Diameter d	d ≤ 1/2	d > 1/2
Hardness (HRC)	39-45	37-45
Tensile Strength (psi)	180,000 min.	170,000 min.
Yield Strength at 0.2% Offset (psi)	153,000 min.	153,000 min.
Elongation (%)	10 min.	10 min.

DIN 7991 Flat Head Countersunk Socket Cap Screws	
Property Class	10.9
Hardness (HRC)	32-39
Tensile Strength (Mpa)	835 min.

ASME B18.3 Flat Head Countersunk Socket Cap Screws		
Diameter d	d ≤ 1/2	d > 1/2
Hardness (HRC)	39-44	37-44
Tensile Strength (psi)	145,000 min.	135,000 min.

ISO 7380 Button Head Socket Cap Screws	
Property Class	10.9
Hardness (HRC)	32-39
Tensile Strength (Mpa)	835 min.

ASME B18.3 Button Head Socket Cap Screws		
Diameter d	d ≤ 1/2	d > 1/2
Hardness (HRC)	39-44	37-44
Tensile Strength (psi)	145,000 min.	135,000 min.



Mechanical Properties for Hex Products

ISO 4014 / 4017 Hex Head Bolts		
Property Class	10.9	12.9
Hardness (HRC)	32-39	39-44
Tensile Strength (Mpa)	1,040 min.	1,220 min.
Yield Strength at 0.2% Offset (Mpa)	940 min.	1,100 min.
Elongation (%)	9 min.	8 min.

ISO 4162 Hexagon Flange Bolts		
Property Class	10.9	12.9
Hardness (HRC)	32-39	39-44
Tensile Strength (Mpa)	1,040 min.	1,220 min.
Yield Strength at 0.2% Offset (Mpa)	940 min.	1,100 min.
Elongation (%)	9 min.	8 min.

ASME B18.2.1 Hexagon Head Cap Screws	
Property Class	SAE J429-Grade 8
Hardness (HRC)	33-39
Surface Hardness (30N)	58.6 max.
Tensile Strength (psi)	150,000 min.
Yield Strength at 0.2% Offset (psi)	130,000 min.
Elongation (%)	12 min.

IFI-111 Hexagon Flange Screws	
Property Class	SAE J429-Grade 8
Hardness (HRC)	33-39
Surface Hardness (30N)	58.6 max.
Tensile Strength (psi)	150,000 min.
Yield Strength at 0.2% Offset (psi)	130,000 min.
Elongation (%)	12 min.